

FORM PTO-1390 (Modified) (REV 11-98)	U.S. DEPARTMENT OF COMMERCE PATENT AND TRADEMARK OFFICE	ATTORNEY'S DOCKET NUMBER RCA 89131
TRANSMITTAL LETTER TO THE UNITED STATES DESIGNATED/ELECTED OFFICE (DO/EO/US) CONCERNING A FILING UNDER 35 U.S.C. 371		U.S. APPLICATION NO. (IF KNOWN, SEE 37 CFR <b>09/743653</b> )

INTERNATIONAL APPLICATION NO. PCT/US99/16188	INTERNATIONAL FILING DATE 15 July 1999 (15.07.99)	PRIORITY DATE CLAIMED 17 July 1998 (17.07.98)
---	--	--

TITLE OF INVENTION  
A CONDITIONAL ACCESS SYSTEM FOR BROADCAST DIGITAL TELEVISION

APPLICANT(S) FOR DO/EO/US  
Ahmet Mursit Eskicioglu; William Wesley Beyers; Izzat Hekmat Izzat;  
Edwin Arturo Heredia; Yousef Wasef Nijim

Applicant herewith submits to the United States Designated/Elected Office (DO/EO/US) the following items and other information:

1.  This is a **FIRST** submission of items concerning a filing under 35 U.S.C. 371.
2.  This is a **SECOND** or **SUBSEQUENT** submission of items concerning a filing under 35 U.S.C. 371.
3.  This is an express request to begin national examination procedures (35 U.S.C. 371(f)) at any time rather than delay examination until the expiration of the applicable time limit set in 35 U.S.C. 371(b) and PCT Articles 22 and 39(1).
4.  A proper Demand for International Preliminary Examination was made by the 19th month from the earliest claimed priority date.
5.  A copy of the International Application as filed (35 U.S.C. 371 (c) (2))
  - a.  is transmitted herewith (required only if not transmitted by the International Bureau).
  - b.  has been transmitted by the International Bureau.
  - c.  is not required, as the application was filed in the United States Receiving Office (RO/US).
6.  A translation of the International Application into English (35 U.S.C. 371(c)(2)).
7.  A copy of the International Search Report (PCT/ISA/210). attached to Item 13
8.  Amendments to the claims of the International Application under PCT Article 19 (35 U.S.C. 371 (c)(3))
  - a.  are transmitted herewith (required only if not transmitted by the International Bureau).
  - b.  have been transmitted by the International Bureau.
  - c.  have not been made; however, the time limit for making such amendments has NOT expired.
  - d.  have not been made and will not be made.
9.  A translation of the amendments to the claims under PCT Article 19 (35 U.S.C. 371(c)(3)).
10.  An oath or declaration of the inventor(s) (35 U.S.C. 371 (c)(4)).
11.  A copy of the International Preliminary Examination Report (PCT/IPEA/409).
12.  A translation of the annexes to the International Preliminary Examination Report under PCT Article 36 (35 U.S.C. 371 (c)(5)).

- Items 13 to 20 below concern document(s) or information included:
13.  An Information Disclosure Statement under 37 CFR 1.97 and 1.98. with references attached
  14.  An assignment document for recording. A separate cover sheet in compliance with 37 CFR 3.28 and 3.31 is included.
  15.  A **FIRST** preliminary amendment.
  16.  A **SECOND** or **SUBSEQUENT** preliminary amendment.
  17.  A substitute specification.
  18.  A change of power of attorney and/or address letter.
  19.  Certificate of Mailing by Express Mail
  20. Return postcard receipt

~~XXXXXX Other items or information~~ **CERTIFICATE OF MAILING UNDER 37 CFR 1.10**

EL667108853US 12 January 2001  
 "Express Mail" mailing no. Date of Deposit

I hereby certify that this application is being deposited with the United States Postal Service "Express Mail Post Office to Addressee" service under 37 CFR 1.10 on the date indicated above and is addressed to the Assistant Commissioner for Patents, Washington, D.C. 20231.

DAVIDA FORNAROTTO David Fornarotto  
 Typed or printed name of person mailing application Signature of person mailing application

U.S. APPLICATION NO. (IF KNOWN, SEE 37 CFR 1.492) 09/743653 INTERNATIONAL APPLICATION NO. PCT/US99/16183 ATTORNEY'S DOCKET NUMBER RCA 89131

21. The following fees are submitted:
- BASIC NATIONAL FEE ( 37 CFR 1.492 (a) (1) - (5) ) :**
- Neither international preliminary examination fee (37 CFR 1.482) nor international search fee (37 CFR 1.445(a)(2)) paid to USPTO and International Search Report not prepared by the EPO or JPO .....\$1000.00
  - International preliminary examination fee (37 CFR 1.482) not paid to USPTO but International Search Report prepared by the EPO or JPO ..... \$860.00
  - International preliminary examination fee (37 CFR 1.482) not paid to USPTO but international search fee (37 CFR 1.445(a)(2)) paid to USPTO ..... \$710.00
  - International preliminary examination fee paid to USPTO (37 CFR 1.482) but all claims did not satisfy provisions of PCT Article 33(1)-(4) .....\$690.00
  - International preliminary examination fee paid to USPTO (37 CFR 1.482) and all claims satisfied provisions of PCT Article 33(1)-(4) ..... \$100.00

CALCULATIONS PTO USE ONLY	
<b>ENTER APPROPRIATE BASIC FEE AMOUNT =</b>	860.00

Surcharge of \$130.00 for furnishing the oath or declaration later than  20  30 months from the earliest claimed priority date (37 CFR 1.492 (e)).

CLAIMS	NUMBER FILED	NUMBER EXTRA	RATE
Total claims	6 - 20 =	0	x \$18.00
Independent claims	1 - 3 =	0	x \$80.00
Multiple Dependent Claims (check if applicable). <input type="checkbox"/>			

**TOTAL OF ABOVE CALCULATIONS = 860.00**

Reduction of 1/2 for filing by small entity, if applicable. Verified Small Entity Statement must also be filed (Note 37 CFR 1.9, 1.27, 1.28) (check if applicable).

**SUBTOTAL = 860.00**

Processing fee of \$130.00 for furnishing the English translation later than  20  30 months from the earliest claimed priority date (37 CFR 1.492 (f)). +

**TOTAL NATIONAL FEE = 860.00**

Fee for recording the enclosed assignment (37 CFR 1.21(h)). The assignment must be accompanied by an appropriate cover sheet (37 CFR 3.28, 3.31) (check if applicable).

**TOTAL FEES ENCLOSED = 860.00**

<b>Amount to be refunded</b>	\$
<b>charged</b>	\$ 860.00

- A check in the amount of \_\_\_\_\_ to cover the above fees is enclosed.
- Please charge my Deposit Account No. 07-0832 in the amount of \$860.00 to cover the above fees. A duplicate copy of this sheet is enclosed.
- The Commissioner is hereby authorized to charge any fees which may be required, or credit any overpayment to Deposit Account No. 07-0832 A duplicate copy of this sheet is enclosed.

NOTE: Where an appropriate time limit under 37 CFR 1.494 or 1.495 has not been met, a petition to revive (37 CFR 1.137(a) or (b)) must be filed and granted to restore the application to pending status.

SEND ALL CORRESPONDENCE TO:

Mr. Joseph S. Tripoli  
 THOMSON multimedia Licensing Inc.  
 Patent Department  
 PO Box 5312  
 Princeton, New Jersey 08540

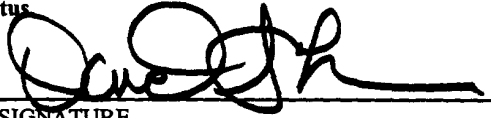
  
 SIGNATURE

David T. Shoneman  
 NAME

39,371  
 REGISTRATION NUMBER

January 12, 2001  
 DATE

NOT FOR PROCESSING

IN THE UNITED STATES PATENT AND TRADEMARK OFFICE

Applicant : Ahmet Mursit Eskicioglu; William Wesley Beyers;  
Izzat Hekmat Izzat; Edwin Arturo Heredia;  
Yousef Wasef Nijim  
Filed : Herewith  
For : A CONDITIONAL ACCESS SYSTEM FOR BROADCAST  
DIGITAL TELEVISION

PRELIMINARY AMENDMENT

Hon. Commissioner of Patents and Trademarks  
Box PCT  
Washington, D.C. 20231

Sir:

In the US national phase application of PCT/US99/16188 filed  
herewith, please enter the following amendments:

IN THE SPECIFICATION:

Please amend the specification as follows:

On Page 1, following the title, insert:

-- This application claims the benefit under 35 U.S.C. § 365  
of International Application PCT/US99/16188, filed July 15, 1999, which claims  
the benefit of U.S. Provisional Application Serial No. 60/093,223, filed July 17,  
1998. --

IN THE ABSTRACT:

Please add the following Abstract.

-- A method for managing access to scrambled broadcast or  
transmitted events received from a variety of service providers (including broadcast  
television networks, cable television networks, digital satellite systems). Each  
service provider employs the same public key for descrambling the access  
information message thereby permitting a user to access events from various service  
providers without changing the smart card. The method may also be expanded to  
manage access to a scrambled package of broadcast events.--

PCT/US99/16188

## REMARKS

The specification has been amended to include a reference to the priority application.

To meet the requirements of the United States, the Abstract (as amended during the prosecution of the PCT application) is added. To meet the requirements of the United States Patent and Trademark Office, reference indicia has been delete.

No fee is believed to have been incurred by virtue of this amendment. However if a fee is incurred on the basis of this amendment, please charge such fee against deposit account 07-0832

Respectfully submitted,  
Ahmet Mursit Eskicioglu  
William Wesley Beyers  
Izzat Hekmat Izzat  
Edwin Arturo Heredia  
Yousef Wasef Nijim



David T. Shoreman Attorney  
Registration No. 39,371  
609/734-9875

THOMSON multimedia Licensing Inc.  
Patent Operation  
PO Box 5312  
Princeton, NJ 08543-5312

January 12, 2001

PTO/PCT Rec'd 12 JAN 2000

A CONDITIONAL ACCESS SYSTEM FOR BROADCAST DIGITAL  
TELEVISION

Field of the Invention

5

This invention concerns a system that may be employed to provide conditional access to multiple broadcasters by a single consumer electronic device, such as a set-top box or a digital television. Each device is capable of receiving broadcast or transmitted digital streams from a variety of broadcast sources.

10

Background of the Invention

Today's NTSC televisions receive broadcast services from a variety of service providers (see Figure 1). Most television receivers are capable of receiving unscrambled, information or programs directly from broadcast 22, satellite 26 and cable 24 networks. Traditionally, cable networks 24 providing scrambled or encrypted programs usually require a separate stand-alone device 16a (e.g., a set-top box) to descramble or decrypt the program. Similarly, digital satellite systems usually provide scrambled or encrypted programs that also require the use of a separate set-top box 16b. These set-top boxes may utilize a removable smart card 18a, 18b which contain the necessary decrypting algorithms and keys. Typically, a separate set-top box is required for each service provider.

15  
20  
25

In the near future, broadcast digital television services may comprise 5 to 20 local channels, each of which may broadcast up to 10 simultaneous programs, some of these programs being pay-per-view programs. A user may want a mix of services from several of the different service providers. For example, a user may want to purchase all of the Indiana University basketball games from local channel 4 and purchase all of the Notre Dame football games from channel 13 and purchase all of the Indianapolis Colts games from channel 8. If each of these services were uniquely scrambled, the user would be burdened with purchasing multiple conditional access smart cards and swapping the cards as the user channel surfs.

30  
35

Summary of the Invention

The present invention resides, in part, in recognition of the described problem and, in part, in providing a solution to the problem. A  
5 single conditional access system that is capable of being used with a plurality of service providers without changing security modules is provided. Such a global conditional access system employs the concept of automatically debiting a user's account as a program is purchased versus logging all purchases and transmitting the log to the service provider for billing. To  
10 achieve the desired flexibility, the system employs a global public key that is used by all of the service providers; this is the public key for every smart card. The corresponding private key is loaded into the smart card. It is well within the teachings of this application that more than one public/private key pair may be used to minimize the impact should security be breached.

15 An event or program as described herein comprises one of the following: (1) audio/visual data such as a movie, weekly "television" show or a documentary; (2) textual data such as an electronic magazine, paper, or weather news; (3) computer software; (4) binary data such as images or (5)  
20 HTML data (e.g., web pages). The service providers include any provider broadcasting events, for example, traditional broadcast television networks, cable networks, digital satellite networks, providers of electronic list of events, such as electronic program guide providers, and in certain cases internet service providers.

25 Such a system can be based on public key technology. One public key (number) is available to all service providers. This is the public key for every smart card. Each smart card has stored therein a secret private key that can decrypt messages encrypted by the public key. The service provider  
30 sends a CA entitlement message in the transmission stream encrypted by the public key that contains the name of the service provider, the name, time, and cost of the program and the key to decrypt the keys used to scramble the program. This message is decrypted by the smart card, and the appropriate information is stored in the smart card for each event purchased. The smart  
35 card has a certain amount of credit for purchases that has been enabled by the bank. As long as the limit is not exceeded, programs can be purchased by the viewer. At some appropriate preprogrammed time, the smart card forces a telephone call to the CA center. Using another set of public and private keys,

the CA center in cooperation with a bank receives billing information from the smart card and provides additional credit. The bank forwards the information and credits the appropriate service provider.

5                   Generally, the present invention defines a method for providing conditional access to a restricted broadcast or transmitted event. First encrypted access information associated with the broadcast event is received. Next the access information is decrypted (or descrambled) and the cost of said broadcast event is verified to determine if it is less than a pre-stored cash  
10                   reserve. Then the scrambled broadcast event is received from the service provider and it is descrambled.

                    In accordance with one aspect of the present invention, the method for managing access to a restricted broadcast or transmitted event  
15                   from one of a plurality of service providers comprises receiving a plurality of access information messages associated with the transmitted event. Each of the access information messages being scrambled using a different public key and comprising data corresponding to the cost of the transmitted event. Then, decrypting or descrambling one of the access information messages using  
20                   the pre-stored private key associated with the service provider and verifying that the cost of the transmitted event is less than a pre-stored cash reserve. Finally, receiving the scrambled transmitted event from one of the service providers and descrambling the transmitted event using the descrambling key.

25                   In accordance with another aspect of the present invention the method for managing access to a restricted transmitted package of events comprises receiving digitally signed access information associated with the package of events via a direct channel and comprising data corresponding to the cost of the package of events. The signature on the access information is  
30                   verified using a public key; the cost of the package is checked to ensure that it is less than a pre-stored cash reserve. When any one of the scrambled broadcast events belonging to the package is received from the service provider, its access information is decrypted to obtain the descrambling key.

35                   In accordance with yet another aspect of the present invention the method for managing access to a restricted transmitted event comprises transferring, from a bank, a cash reserve to a smart card; receiving, from a service provider, an encrypted event key and the cost of the event; passing

the event key and purchase information to the smart card which is coupled to the digital video apparatus. Next, the cost of the event is verified to determine that it is less than the stored cash reserve and the cost is deducted. The encrypted event key is decrypted and the scrambled event is received and then passed to the smart card where it is descrambled using the decrypted event key. Finally, the descrambled event is transferred to the digital video apparatus.

These and other aspects of the invention will be explained with reference to a preferred embodiment of the invention shown in the accompanying Drawings.

#### Brief Description of the Drawing

Figure 1 is a block diagram illustrating a prior art configuration for interconnecting consumer electronic devices to a variety of service providers.

Figure 2 is a block diagram illustrating one architecture for interfacing a common digital television to a plurality of terrestrial broadcasters; and

Figure 3 is a block diagram of an exemplary implementation of a system for managing access to a device in accordance with the invention.

#### Detailed Description of the Drawing

The present invention provides a conditional access system, which may be utilized to obtain services from one of a plurality of sources. The conditional access system when implemented within a digital television (DTV), or set-top box or the like, permits a user to receive scrambled events from more than one service provider without swapping conditional access modules or smart cards. Alternately, the functionality of the smart card may be embedded within the DTV. Such a conditional access system may act as a toll bridge for access to services thereby permitting a mechanism for the manufacturer of the DTV to collect fees based on use of its DTV. Similarly, this invention may be implemented within a set-top box (STB); for simplicity, the below description of the invention will be directed towards an implementation using a digital television and a smart card coupled thereto.



In Figure 2, system 30 depicts the general architecture for managing access to a digital television (DTV) 40a, 40b. For simplicity the following description will be limited to a single DTV 40a. Similar element numbers define the same functional element. Smart Card (SC) 42a is inserted into or coupled to a smart card reader (not shown) of DTV 40a; bus 45 interconnects DTV 40a and SC 42a thereby permitting the transfer of data therebetween. Such smart cards include, for example, ISO 7816 cards complying with National Renewable Security Standard (NRSS) Part A or PCMCIA cards complying with NRSS Part B. This inventive concept is not limited to smart cards per se, but can be employed with conditional access modules. Conceptually, when such a smart card is coupled to a smart card reader, the functionality of the smart card may be considered to be a part of the functionality of the digital television thus removing the "boundaries" created by the physical card body of the smart card.

DTV 40a can receive services from a plurality of service providers (SPs), such as a broadcast television SPs 50 and 52, a cable television (not shown), and a satellite system (not shown). This invention finds benefit in terrestrial broadcasting. Certificate authority (CA) 75 is not directly connected to either the service providers or DTV 40a but issues digital certificates and public and private key pairs, which are used as, explained below. It is within the scope of this invention that the role of certificate authority 75 may be performed by the service providers in collaboration with the manufacturer of the DTV 40a. Billing center 70 is utilized to manage the user's accounts; updated information is provided as users make arrangements to purchase additional services and as these services are consumed or used.

Such a Conditional Access (CA) system designed for DTV broadcast technology is a transport-based system. This means that CA information for a particular broadcaster is transmitted only on its own RF channel. Each broadcaster is responsible for its own information and hence, there is no need for pre-established code of conducts to coordinate and/or synchronize information among several broadcasters. Further, the CA system is based on E-cash card loading. A user pre-loads his/her card with a certain amount of cash (from debit or credit accounts), and then uses the card to buy event packages, pay for monthly subscriptions, or buy specific programs in PPV mode. An event package may include, for example, all the games of

your favorite professional sports franchise or all the late Sunday movies on one or more virtual channels.

5 The broadcast channel is used only to deliver the services and information for access to these services. All the remaining transactions are carried out using a return channel (i.e., a modem and a phone connection). Broadcasting of addressable messages is not needed. The broadcast services are protected using a common scrambling algorithm. The keys used in this process and event purchase information are encrypted with a global public key, and delivered to the user via the MPEG-2 stream. For event packages, package certificates are sent to the user, from the CA server 60a, via the return channel. As described below in more detail, certificates are usually signed to ensure integrity of the certificate. That is, to ensure that the proper and unmodified certificate is received from the sender. Services are accessed through a renewable security module, i.e., and a smart card.

20 Symmetric key cryptography involves the use of the same algorithm and key for both encryption and decryption. The foundation of public-key cryptography is the use of two related keys, one public and one private. The private key is a secret key and it is computationally unfeasible to deduce the private key from the public key, which is publicly available. Anyone with a public key can encrypt a message but only the person or device having the associated and predetermined private key can decrypt it. Similarly, a message can be encrypted by a private key and anyone with access to the public key can decrypt that message. Encrypting messages using a private key may be referred to as "signing" because anyone holding the public key can verify that the message was sent by the party having the private key. This may be thought of as being analogous to verifying a signature on a document.

30 A digitally signed message is a message sent in the clear (i.e., unencrypted) having a signature attached thereto. The attached signature is produced by encrypting either the message itself or a digest of the message; a digest of the message is obtained by hashing the message. (Hashing involves subjecting the message to a one-way hashing algorithm, such as MD5 developed by Ron Rivest or SHA-1 developed by the National Institute of Standards and Technology (NIST) and the National Security Agency (NSA) prior to encrypting the message.) Thus the recipient of the signed message can verify the integrity (i.e., the source or origin) of the message. (In

comparison, a public key certificate or digital certificate is a message, containing a public key sent in the clear having a signature attached thereto.) Signature verification involves checking the signature by decryption.

5 As defined above, the five essential components of the CA system are the broadcaster, the CA vendor, the billing center (e.g., a bank), the end user, and the Certificate Authority. Figure 2 illustrates the overall system architecture, and identifies these five components with their communication links and data flows.

10 The end user communicates with the CA vendor for downloading certificates through a point-to-point link such as a telephone line. The telephone line is used for automatic transactions and for voice connection when necessary. For automatic transactions, one enabling protocol is the  
15 Point-to-Point Protocol (PPP). Security is implemented at the application layer using private protocols.

20 Communication between the CA vendor and the broadcaster may be established through a Local Area Network (LAN) or Wide Area Network (WAN). As before, security is embedded at the application level using privately-defined protocols running over existing internetworking protocols. The broadcast facility equipment needed to protect the broadcast streams can be an off-the-shelf product available from multiple CA vendors.

25 Broadcasters are responsible for delivering: (1) the services, and (2) the entitlement messages. Such entitlement messages include access information (AIM) messages described below in more detail, (or alternatively entitlement control messages and entitlement management messages) that  
30 allow any user to buy those services. Communication between a broadcaster and the user therefore follows the point-to-multipoint model of broadcast technology. Broadcast AIMS do not contain addresses unique to each user or subscriber, which is typical with satellite or cable systems.

35 If DTV 40a does not have a back channel connection needed to communicate with the CA server then loading cash to the card requires the user to either access a DTV unit with back-channel support or go to a particular location (bank, ATM, vendor's regional office) to have the card loaded. The CA operators act like the card holder's or user's bank, while the

5 billing center acts like the merchant's bank. The card association could be the middleman between the CA operators and the broadcasters' banks that provides a transaction settlement service. The fixed amount of "cash" loaded into the smart card or conditional access module can now be used to pay of services offered by a broadcaster.

10 Whichever cash transfer mechanism is employed, the user requests a transfer of a specific amount of money to the CA card from a credit or debit account. After proper verification of the subject's identity and validation of user resources, the transaction is authorized, and the nominal amount of money is stored in the CA card.

15 Once money is loaded into the card, a user can buy any number of services offered by broadcasters. Each purchase reduces the amount of available money in the card by the service price. The services offered by broadcasters can be classified into two categories; PPV events and packages. An event is a TV program with an allocated slot in a program guide and a package is simply a collection of events. Examples of packages are (1) all the NBA games in a given season, (2) the late Sunday movies on one or more virtual channels, (3) subscription to a particular virtual channel such as HBO. All events must have one or more of their audiovisual streams scrambled using a common symmetric key algorithm. Entitlement packages, which contain purchase information and descrambling keys, have to be encrypted with a common public-key algorithm.

25 Upon purchase of an event, a record may be stored in the smart card which may be later transferred to the CA vendor. Once the stored purchase information is sent to the CA database, a CA vendor can pay broadcasters for the provided services. In addition, each smart card has non-volatile memory to keep the following information.

35 A 32-bit field represents the card serial number. A 128-bit BCD field for the user (credit or debit) card number. A 10-byte field for the CA server phone number. A 10-byte field for an alternate CA server phone number. A 40-bit BCD field to store the amount of money available to the user. A field for a signature on the last E-cash certificate. An 8-bit field to store a threshold value to inform the user that the available E-cash is less than

a predetermined threshold or to initiate an automatic call back to the CA server to add money. A 40-bit BCD field for the amount of money downloaded to the card without user involvement when E-cash is less than the threshold. The amount is determined by the user and sent to the CA server during card activation. If this value is zero, automatic E-cash download will not be allowed. Two 768-bit fields for storing the private key for decrypting the AIMS and for storing the public key for verifying the signature on certificates. An 21-byte field for storing the DES key for descrambling the broadcast services. Two 96-byte fields for storing the key to replace the current private key and for the key to replace the current verification key. An 8-byte field for storing the symmetric DES key for secure communication with the CA server is also provided. It is within the scope of this invention that a scrambling algorithm may be a cipher other than DES.

The card must store information for PPV events and the packages purchased by the user. If the card memory is full, the user will not be allowed to purchase additional events.

Data exchange between the card and the host is based on a well-defined common interface, i.e., the National Renewable Security Standard (NRSS), EIA-679 Part A or Part B. Since the phone line is a widely available physical link, the chosen protocol between the CA server and the host is the Point-to-Point protocol (PPP), RFC 1548, adopted as Standard 51 with security provided within PPP datagrams. The technological innovation described herein does not preclude the use of alternative protocols different from PPP on the return channel.

PPP is a protocol based on the HDLC standards of ISO, as adopted by the ITU-T for X.25 systems. It was developed by IETF to transport datagrams from multiple protocols over point-to-point links. The frame format is a 16 bit protocol field (defined in RFC 1700, "Assigned Numbers"), followed by an information field of variable length and then followed by a padding field containing optional bytes added to adjust the frame length (if required by the receiving protocol).

For exchanging data between the card and the CA server, a new protocol is defined, having a protocol field value 0x00FF. The value of the

padding field is always zero for this new protocol. The new protocol provides reliable transmission using acknowledgment (ACK) and negative acknowledgment (NACK) messages which are inserted into the first byte of the Information field both messages utilizing an 8-bit uimsbf format.

5

An ACK may be followed by information (piggyback acknowledgment) sent as a reply. If the receiving end detects a corrupted message, it responds with a NACK, and requests retransmission by the sender.

10

Using the above protocol, the smart card initiates a callback to the CA server under any of the following conditions:

1. The card has been inserted into the DTV for the first time.
2. The user has entered a request for an advanced package purchase using a displayed menu.
3. The smart card memory is full.
4. The local time is within the interval [1am-6am] and there are new records to be sent.
5. The card has received a notification for a new private key or verification key.
6. The smart card money is less than the specified threshold and automatic E-cash download is enabled.
7. The user has entered a request for money using a displayed menu.
8. The user has entered a request to cancel a package purchase.

Depending on the condition, the card sends an initial alerting message to inform the CA server about the user and the purpose of the call.

When the user inserts the card into the DTV for the first time, the information specific to the card is sent to the CA server for registration. This information is encrypted with Kcallback.

Card → CA server: Alert message (with alert\_type = 0x01)

Card ← CA server: ACK message

Card → CA server: Card information message

Card ← CA server: ACK message

35

An advanced purchase can be made using a displayed menu. In response to the user request, the CA server sends a package certificate that will be saved on the card. For example,

Card → CA server: Alert message (with alert\_type = 0x02)

Card ← CA server: ACK message | Signed package certificate message

Card → CA server: ACK message

5

The Package Certificate format contains the following fields.

An 8-bit field that indicates a package certificate message. Two values are possible, one for renewable package subscription and one for non-renewable package subscription. A 32-bit field that identifies the registration authority that assigns values to the provider\_index field. A 16-bit field that identifies the content provider. This unique number is registered with the registration authority identified by the format\_identifier. A 16-bit field that identifies the transport stream where the event is being carried. A 16 bit field that indicates the package identifier. An 8-bit field for the title field. A variable length field for the title of the package using ASCII with Latin-1 extensions. A 40-bit field which indicates the price of the package in BCD format. A 24-bit field which indicates the expiration date of the package.

The PPV event purchase records are temporarily stored in the card until after the event is broadcast. They are sent to the CA server without user involvement and when either

(i) the card memory is unable to store more records or

(ii) the local time is in the interval [1am-6am] and there are new records to be sent.

25

All records are encrypted with Kcallback.

(i) Smart card memory is full

Card → CA server: Alert message (with alert\_type = 0x03)

Card ← CA server: ACK message

Card → CA server: A variable number of encrypted PPV event purchase records

Card ← CA server: ACK message

(ii) The local time is within the interval [1am-6am] and there are new records to be sent

Card → CA server: Alert message (with alert\_type = 0x04)

Card ← CA server: ACK message

Card → CA server: A variable number of encrypted PPV event purchase records

12

Card ← CA server: ACK message

When the private key or verification key needs to be replaced, a notification is sent to the cards using the broadcast channel. Each user is then required to initiate a callback to receive the new key.

5 Card → CA server: Alert message (with alert\_type = 0x05)

Card ← CA server: ACK message | Key replacement message

Card → CA server: ACK message

10 Money is added to the card when;

1. the smart card money is less than a specified threshold or
2. the user enters a request for money using a displayed menu or
3. the card is taken to a remote location (if there is no local phone connection).

15 In all cases, the entity providing the money verifies the credit or debit card information, generates an E-cash Certificate (ECC), and sends it to the card. The ECC message format is an 8-bit field for the message type and 40-bit field to hold the BCD value of the amount of money to be added to the smart card.

20 1) Automatic E-cash download is enabled:

Card → CA server: Alert message (with alert\_type = 0x06)

Card ← CA server: ACK message

Card → CA server: Signature on E-cash

Card ← CA server: ACK | Signed E-cash certificate message

25 Card → CA server: ACK message

2) The E-cash Certificate contains the predefined, fixed amount of E-cash.

Automatic E-cash download is disabled. The user proceeds as follows;

Card → CA server: Alert message (with alert\_type = 0x07)

30 Card ← CA server: ACK message

Card → CA server: Signature on E-cash | E-cash amount message

Card ← CA server: ACK message | Signed E-cash certificate message

Card → CA server: ACK message

35 The user can cancel a purchase by using a menu displayed on the screen. The action taken by the card depends on the type of the purchase:



- (i) Package purchase: A call is initiated to the CA server.  
 Card → CA server: Alert message (with alert\_type = 0x08)  
 Card ← CA server: ACK message  
 Card → CA server: Canceled package purchase record  
 5 Card ← CA server: ACK message | Signed E-cash certificate message  
 Card → CA server: ACK message
- (ii) PPV event purchase: If the deadline for canceling the event has not been reached, the chosen record is deleted entirely.

10

The AIMs are carried as private data in the adaptation field of the Transport Stream packets carrying video data. These AIMs could also be carried in the Transport Stream with different PIDs using the tools and functions available for ECM transmission in MPEG-2. The  
 15 adaptation\_field\_control bits shall be '10' (Adaptation field only, no payload) or '11' (adaptation field followed by payload). The maximum cycle time for AIM messages with the same AIM\_id shall be 500 ms.

The bit-stream syntax for the Access Information Message  
 20 contains the following fields. A unique 8-bit identifier of this access information message. The AIM\_id field is the second byte in the private data section of the adaptation field. The first byte is allocated for identifying the public key used in protecting the AIM (if multiple public keys are used in a given DMA). An 8-bit field specifying the number of bytes in the AIM  
 25 immediately following the AIM\_length field. A 32-bit field that identifies the registration authority that assigns values to the provider\_index field. A 16-bit field that identifies the content provider. This unique number is registered with the registration authority identified by the format\_identifier. A 24-bit field that identifies a particular TV program or event. Assigned by the content provider  
 30 identified by provider\_index, it identifies uniquely all those programs registered in the content provider data base. A 16-bit field that identifies the Transport Stream where the event is being carried. A 16-bit field that identifies uniquely the particular service where the event is being transmitted. A 14-bit field that identifies uniquely a particular event within a given service of this Transport  
 35 Stream. While program\_event\_id is a value that identifies an event for a content provider, event\_id is the program guide index of an event. A broadcaster who acts simultaneously as a content provider may want to have

both numbers equal, but this may not be valid otherwise. A 32-bit field indicating the event start time. A 20-bit field indicating the length of the event measured in seconds. A 10-byte field for storing the first 10 characters of the English title for the event that this message describes. If the actual title has less than 10 characters, then the title segment must be padded with ESC characters before including it in this field. A 5-byte BCD field indicating the cost of the event. A 16-bit field that indicates the packages to which this event belongs. The most-significant bit corresponds to the first package while the least significant bit corresponds to the 16-th package. If the event belongs to the k-th package, then the k-th bit of this field shall be set to one. More than one bit can be set to one to show an event that belongs to multiple packages. A 64-bit field for the DES key (or a 168-bit field for the TDES key) necessary for de-scrambling the video and audio signals for the event under consideration. A 40-bit field indicating that the user needs to obtain a new private key or verification key by calling the CA server. If flag is set to 1, the key needs to be replaced until the indicated deadline. An 8-bit field for identifying the total length (in bytes) of the AIM descriptor list that follows.

In one embodiment of the present invention, entitlement management messages (ECMs) may be used instead of AIMS. The format of the ECM is privately defined according to MPEG-2 and ATSC specifications. A particular format that may be used comprises an 8-bit table identification field, 3 indicator bits, a 12-bit section length field, an 8-bit protocol version field, a 5 bit version number field, 2 section number fields, a public key field, a transport stream identification field, major and minor channel number fields, 2 event identification fields, a stream PID and descriptors length fields, a crypton check field, a stuffing bytes field, and a 32-bit CRC field.

The security of the system is based on standard and widely accepted public key and symmetric key algorithms. The algorithms chosen are RSA for public key encryption and TDES and/or DES for symmetric key scrambling. There is a global RSA public/private key pair, Kpub/Kpri, for the entire system. The public key is shared by all the broadcasters and the corresponding private key is placed in the tamper-proof NRSS-A based smart cards, distributed by the CA providers to the consumers. This public key is used to protect the AIMS generated at the head-end.

The AIMS, encrypted under the public key, carry the control words (CWs) which are symmetric DES keys, KDES, used in scrambling the audio/video content in the ECB mode. After decrypting the AIMS with its private key, the card obtains the DES keys and descrambles audio/video streams. At the head-end: Scrambling:  $E_{KDES}(A/V \text{ stream})$ , Encryption:  $E_{Kpub}(AIM)$ . On the card: Decryption:  $D_{Kpri}(E_{Kpub}(AIM))$ , Descrambling:  $D_{KDES}(E_{KDES}(A/V \text{ stream}))$ .

The security of the system can be improved in a number of ways. One feasible approach is to use multiple public keys at the head-end for encrypting the AIMS. Such use of multiple keys may find benefit in areas of overlapping markets, for example, the user can receive terrestrial digital broadcast from more than major market. Another example would be if the receiver population in a given DMA is divided into distinct subsets and each subset is assigned a different private key, an attack on one private key would not compromise the system.

For example, encryption at the head-end may involve four keys,  $E_{Kpub1}(AIM)$ ,  $E_{Kpub2}(AIM)$ ,  $E_{Kpub3}(AIM)$ ,  $E_{Kpub4}(AIM)$ . Decryption on the card would then be based on one of the following four keys, Card type 1:  $D_{Kpri1}(E_{Kpub1}(AIM))$ , Card type 2:  $D_{Kpri2}(E_{Kpub2}(AIM))$ , Card type 3:  $D_{Kpri2}(E_{Kpub2}(AIM))$ , and Card type 4:  $D_{Kpri4}(E_{Kpub4}(AIM))$ . The public key used in encrypting the AIM is identified using the identifier in the first byte of the adaptation field. This field indicates the public key used in encrypting the AIM. If the value is  $i$ , the active public key is  $Kpub_i$ .

The E-cash Certificates carry the amount of money to be added to the card. The Package Certificates include the price of the package offered to the customer. Since both of the certificates carry sensitive data, there needs to be a signature mechanism to ensure the integrity of these messages. Therefore, all certificates are sent via a channel with a feedback path, for example, a back channel using a MODEM.

Although the Package Certificates are normally sent from the CA server, there may be different sources (e.g., ATMs or other special terminals) for downloading E-cash to the card. If each source signs with a unique private key, the DTV needs to keep multiple public keys. The present CA system

employs an ID-based authentication scheme to allow signature verification using only one public key.

5 As mentioned earlier, to participate in the scrambling, encryption and signature protocols, the broadcasters, CA servers and the smart cards will need to store certain keys. The storage and use of all types of keys are summarized in Figure 3.

10 Kpub is kept at the broadcaster site, and is used to encrypt the DES keys that are locally generated to scramble the A/V streams. The card has the corresponding Kpri for recovering the DES keys.

15 Ksig is used to sign package and E-cash certificates. The signed certificates are verified with Kver stored on the card. In the ID-based scheme described in Section 8.2, Ksig is unique for each certificate provider (CA vendors, ATMs, etc.) but Kver is common to all certificate providers.

20 Kcallback is shared between the card and the CA server, and is used to encrypt sensitive information exchanged. The information sent from the card to the CA server is payment card no, fixed E-cash and event purchase records. When needed, Kpri and Kver are replaced by the CA server. Kcallback may be unique for each card. Its replacement is only possible by sending a new card to the user.

25 While the invention has been described in detail with respect to numerous embodiments thereof, it will be apparent that upon reading and understanding of the foregoing, numerous alterations to the described embodiment will occur to those skilled in the art and it is intended to include such alterations within the scope of the appended claims. For example, this  
30 invention may be utilized successfully with both digital terrestrial broadcast and transmitted satellite digital signals.

## Claims

1. A method for managing access to a restricted transmitted event, said method comprising:
  - (a) receiving encrypted access information associated with said transmitted event, said access information comprising data corresponding to the cost of said transmitted event;
  - (b) decrypting said access information in a conditional access module;
  - (c) verifying, in said conditional access module, that the cost of said transmitted event is less than a pre-stored cash reserve;
  - (d) receiving said transmitted event from said service provider, said transmitted event being scrambled; and
  - (e) descrambling said transmitted event in said conditional access module.
2. The method of Claim 1 wherein said access information further comprises an event descrambling key and purchase information, said purchase information comprising channel identification data, event identity data, date and time stamp data, and billing data.
3. The method of Claim 2 further comprising the step of transferring data associated with said purchased transmitted event to said service provider to update a user's account information.
4. The method of Claim 3, wherein said conditional access module comprises a smart card, and said encrypted access information is encrypted using a public key and decrypted using a corresponding private key stored in said smart card.

5. The method of claim 4 wherein said public key is shared by all broadcasters.
  
6. The method of Claim 5 wherein said smart card comprises a card body with a plurality of terminals arranged on a surface of said card body in accordance with one of ISO 7816 and PCMCIA card standards.

11/11/00 11:11:11 AM

1/3

10

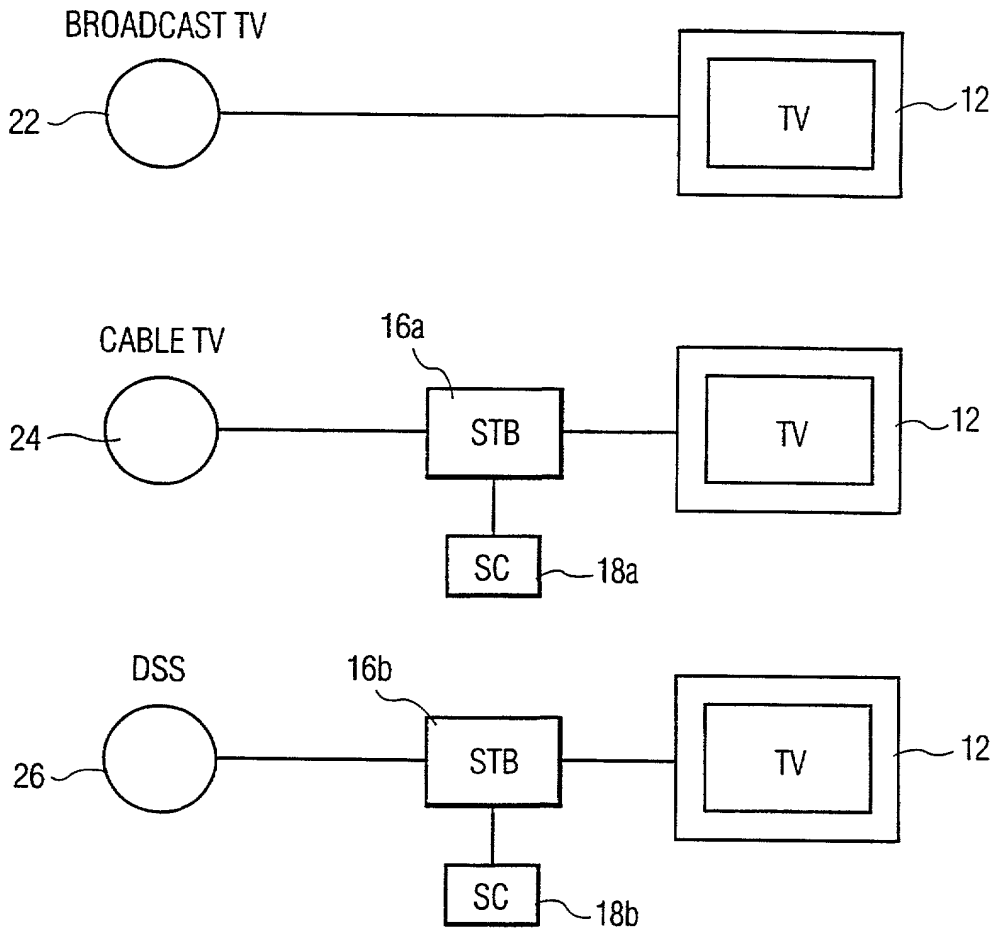

FIG. 1  
PRIOR ART

FIG. 1

30

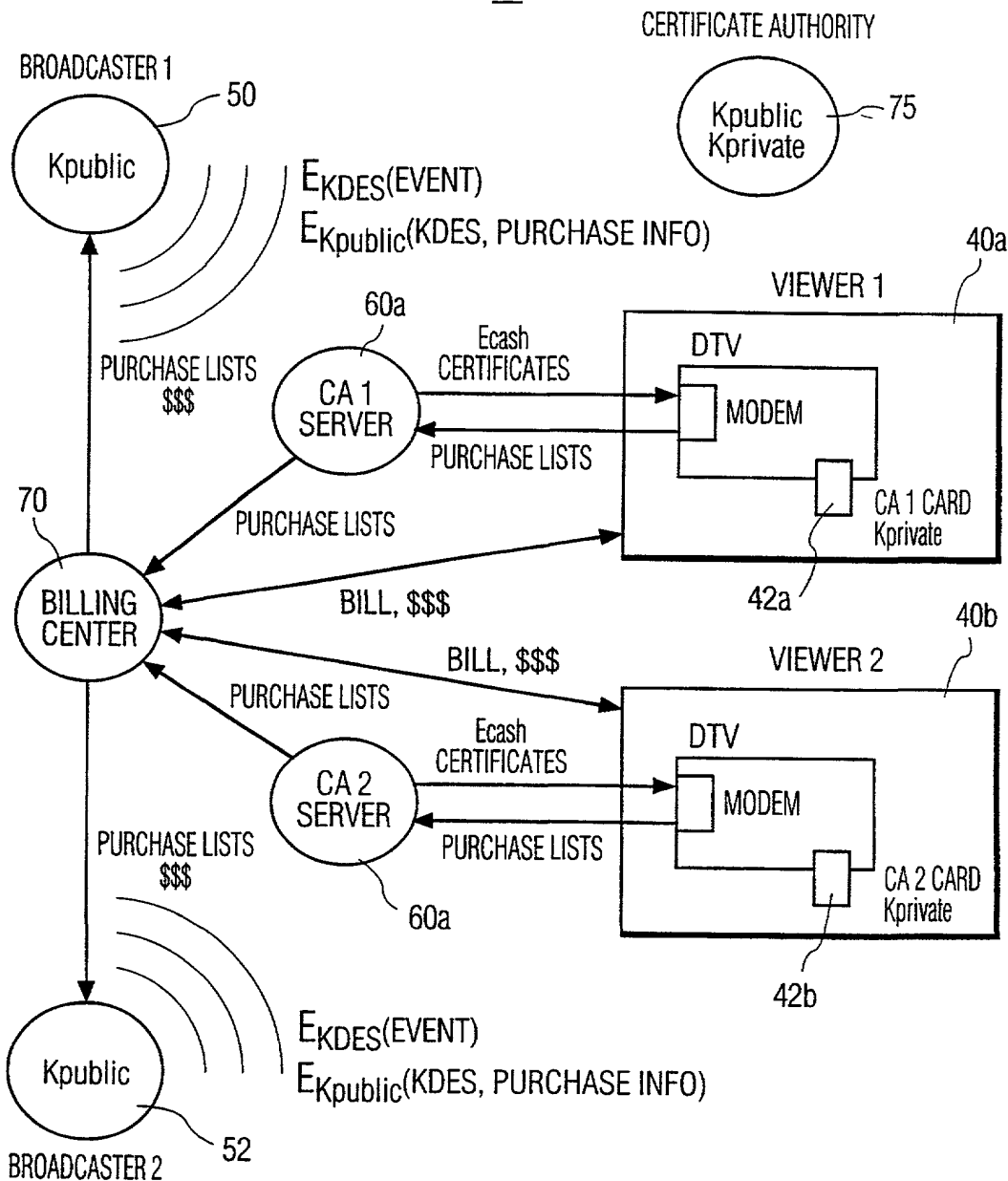

FIG. 2

FOR PUBLICATION



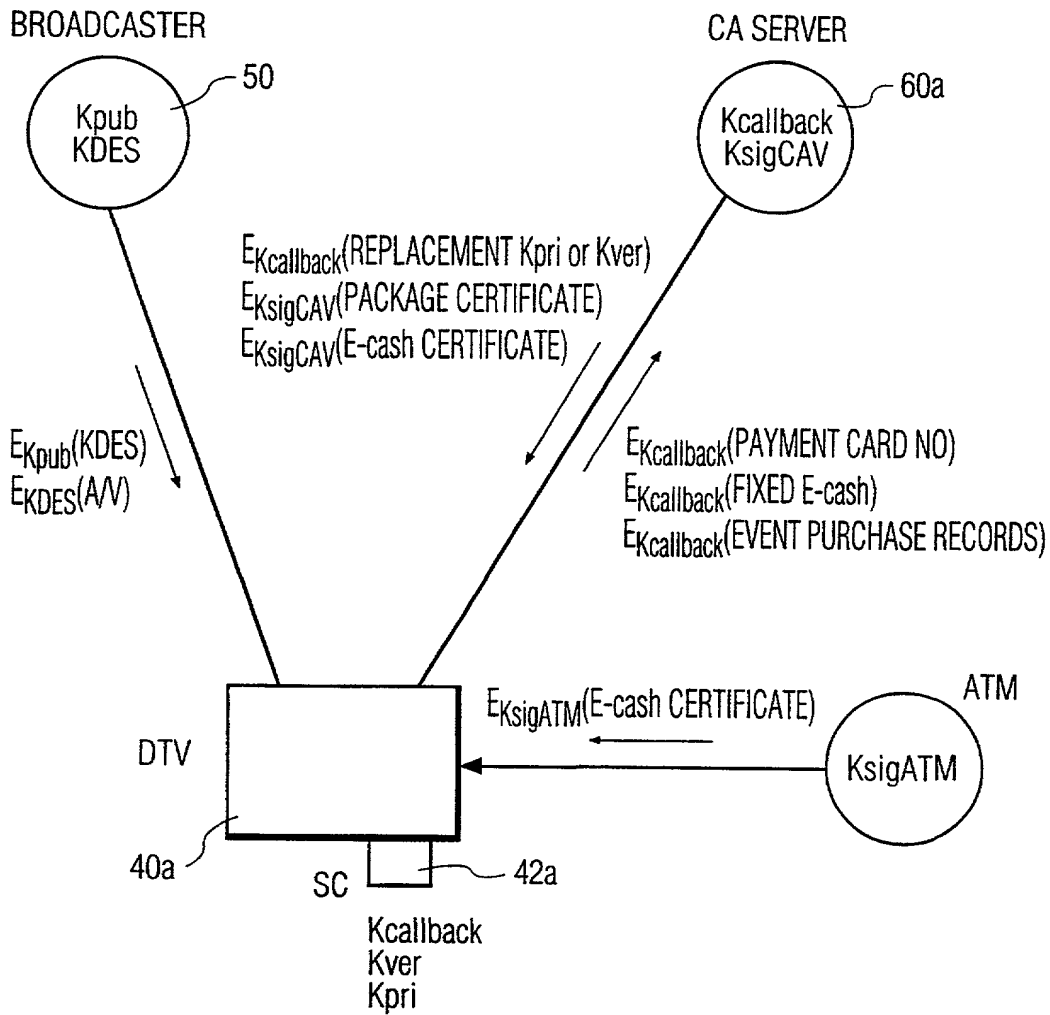

FIG. 3

EXPRESS MAIL #682441975 US

Please type a plus sign (+) inside this box →

PTO/SB/01 (10-00)  
 Approved for use through 10/31/2002. OMB 0651-0032  
 Patent and Trademark Office: U.S. DEPARTMENT OF COMMERCE

Under the Paperwork Reduction Act of 1995, no persons are required to respond to a collection of information unless it contains a valid OMB control number.

<b>DECLARATION FOR UTILITY OR DESIGN PATENT APPLICATION</b> (37 CFR 1.63)  <input type="checkbox"/> Declaration Submitted with Initial Filing    OR <input checked="" type="checkbox"/> Declaration Submitted after Initial Filing (surcharge (37 CFR 1.16(e)))	<b>Attorney Docket Number</b> RCA 89131	
	<b>First Named Inventor</b> Ahmet Mursit Eskicioglu	
	<b>COMPLETE IF KNOWN</b>	
	<b>Application Number</b> /	
	<b>Filing Date</b> /	
	<b>Group Art Unit</b> /	
<b>Examiner Name</b> /		

**As a below named inventor, I hereby declare that:**

My residence, mailing address, and citizenship are as stated below next to my name.

I believe I am the original, first and sole inventor (if only one name is listed below) or an original, first and joint inventor (if plural names are listed below) of the subject matter which is claimed and for which a patent is sought on the invention entitled:

**A CONDITIONAL ACCESS SYSTEM FOR BROADCAST DIGITAL TELEVISION**

the specification of which (Title of the Invention)

is attached hereto  
 OR  
 was filed on (MM/DD/YYYY) **July 15, 1999** as United States Application Number or PCT International Application Number **PCT/US99/16188** and was amended on (MM/DD/YYYY) **September 21, 2000** (if applicable).

I hereby state that I have reviewed and understand the contents of the above identified specification, including the claims, as amended by any amendment specifically referred to above.

I acknowledge the duty to disclose information which is material to patentability as defined in 37 CFR 1.56, including for continuation-in-part applications, material information which became available between the filing date of the prior application and the national or PCT international filing date of the continuation-in-part application.

I hereby claim foreign priority benefits under 35 U.S.C. 119(a)-(d) or 365(b) of any foreign application(s) for patent or inventor's certificate, or 365(a) of any PCT international application which designated at least one country other than the United States of America, listed below and have also identified below, by checking the box, any foreign application for patent or inventor's certificate, or any PCT international application having a filing date before that of the application on which priority is claimed.

Prior Foreign	Foreign Filing Date	Priority	Certified Copy Attached?	
			YES	NO
		<input type="checkbox"/>	<input type="checkbox"/>	<input type="checkbox"/>
		<input type="checkbox"/>	<input type="checkbox"/>	<input type="checkbox"/>
		<input type="checkbox"/>	<input type="checkbox"/>	<input type="checkbox"/>
		<input type="checkbox"/>	<input type="checkbox"/>	<input type="checkbox"/>

Additional foreign application numbers are listed on a supplemental priority data sheet PTO/SB/02B attached hereto:

I hereby claim the benefit under 35 U.S.C. 119(e) of any United States provisional application(s) listed below.

Application Number(s)	Filing Date (MM/DD/YYYY)
60/093,223	July 17, 1998

Additional provisional application numbers are listed on a supplemental priority data sheet PTO/SB/02B attached hereto.

Burden Hour Statement: This form is estimated to take 21 minutes to complete. Time will vary depending upon the needs of the individual case. Any comments on the amount of time you are required to complete this form should be sent to the Chief Information Officer, U.S. Patent and Trademark Office, Washington, DC 20231. DO NOT SEND FEES OR COMPLETED FORMS TO THIS ADDRESS. SEND TO: Assistant Commissioner for Patents, Washington, DC 20231.

Please type a plus sign (+) inside this box →

Under the Paperwork Reduction Act of 1995, no persons are required to respond to a collection of information unless it contains a valid OMB control number.

<b>DECLARATION FOR UTILITY OR DESIGN PATENT APPLICATION</b> <b>(37 CFR 1.63)</b>  <input type="checkbox"/> Declaration Submitted with Initial Filing    OR <input checked="" type="checkbox"/> Declaration Submitted after Initial Filing (surcharge (37 CFR 1.16(e)))	<b>Attorney Docket Number</b>	RCA 89131
	<b>First Named Inventor</b>	Ahmet Mursit Eskicioglu
	<b>COMPLETE IF KNOWN</b>	
	Application Number	/
	Filing Date	
	Group Art Unit	
Examiner Name		

**As a below named inventor, I hereby declare that:**

My residence, mailing address, and citizenship are as stated below next to my name.

I believe I am the original, first and sole inventor (if only one name is listed below) or an original, first and joint inventor (if plural names are listed below) of the subject matter which is claimed and for which a patent is sought on the invention entitled:

**A CONDITIONAL ACCESS SYSTEM FOR BROADCAST DIGITAL TELEVISION**

the specification of which *(Title of the Invention)*

is attached hereto  
 OR  
 was filed on (MM/DD/YYYY) July 15, 1999 as United States Application Number or PCT International Application Number PCT/US99/16188 and was amended on (MM/DD/YYYY) September 21, 2000 (if applicable).

I hereby state that I have reviewed and understand the contents of the above identified specification, including the claims, as amended by any amendment specifically referred to above:

I acknowledge the duty to disclose information which is material to patentability as defined in 37 CFR 1.56, including for continuation-in-part applications, material information which became available between the filing date of the prior application and the national or PCT international filing date of the continuation-in-part application.

I hereby claim foreign priority benefits under 35 U.S.C. 119(a)-(d) or 365(b) of any foreign application(s) for patent or inventor's certificate, or 365(a) of any PCT international application which designated at least one country other than the United States of America, listed below and have also identified below, by checking the box, any foreign application for patent or inventor's certificate, or any PCT international application having a filing date before that of the application on which priority is claimed.

Prior Foreign	Foreign Filing Date	Priority	Certified Copy Attached?	
			YES	NO
		<input type="checkbox"/>	<input type="checkbox"/>	<input type="checkbox"/>
		<input type="checkbox"/>	<input type="checkbox"/>	<input type="checkbox"/>
		<input type="checkbox"/>	<input type="checkbox"/>	<input type="checkbox"/>
		<input type="checkbox"/>	<input type="checkbox"/>	<input type="checkbox"/>

Additional foreign application numbers are listed on a supplemental priority data sheet PTO/SB/02B attached hereto:

I hereby claim the benefit under 35 U.S.C. 119(e) of any United States provisional application(s) listed below.

Application Number(s)	Filing Date (MM/DD/YYYY)	<input type="checkbox"/> Additional provisional application numbers are listed on a supplemental priority data sheet PTO/SB/02B attached hereto.
60/093,223	July 17, 1998	

**Burden Hour Statement:** This form is estimated to take 21 minutes to complete. Time will vary depending upon the needs of the individual case. Any comments on the amount of time you are required to complete this form should be sent to the Chief Information Officer, U.S. Patent and Trademark Office, Washington, DC 20231. DO NOT SEND FEES OR COMPLETED FORMS TO THIS ADDRESS. SEND TO: Assistant Commissioner for Patents, Washington, DC 20231.

# DECLARATION — Utility or Design Patent Application

Direct all correspondence to: <input type="checkbox"/> Customer Number or Bar Code Label <input style="width: 100px; height: 20px;" type="text"/>		OR <input checked="" type="checkbox"/> Correspondence address below	
<b>Name</b> JOSEPH S. TRIPOLI - PATENT OPERATIONS			
<b>Address</b> THOMSON multimedia Licensing Inc.			
<b>Address</b> PO Box 5312			
<b>City</b> PRINCETON		<b>State</b> NJ	<b>ZIP</b> 08540
<b>Country</b> US	<b>Telephone</b> 609-734-9875		<b>Fax</b> 1-609-734-9700
<p>I hereby declare that all statements made herein of my own knowledge are true and that all statements made on information and belief are believed to be true; and further that these statements were made with the knowledge that willful false statements and the like so made are punishable by fine or imprisonment, or both, under 18 U.S.C. 1001 and that such willful false statements may jeopardize the validity of the application or any patent issued thereon.</p>			
<b>NAME OF SOLE OR FIRST INVENTOR :</b>		<input type="checkbox"/> A petition has been filed for this unsigned inventor	
<b>Given Name (first and middle [if any])</b> AHMET MURSIT		<b>Family Name or Surname</b> ESKICIOGLU	
<b>Inventor's Signature</b>			<b>Date</b>
<b>Residence: City</b> INDIANAPOLIS	<b>State</b> IN	<b>Country</b> US	<b>Citizenship</b> TR
<b>Mailing Address</b> 8235 Lakeshore Trail Apt. 125			
<b>Mailing Address</b>			
<b>City</b> Indianapolis	<b>State</b> IN	<b>ZIP</b> 46250	<b>Country</b> US
<b>NAME OF SECOND INVENTOR:</b>		<input type="checkbox"/> A petition has been filed for this unsigned inventor	
<b>Given Name (first and middle [if any])</b> WILLIAM WESLEY		<b>Family Name or Surname</b> BEYERS	
<b>Inventor's Signature</b>			<b>Date</b>
<b>Residence: City</b> Carmel	<b>State</b> IN	<b>Country</b> US	<b>Citizenship</b> US
<b>Mailing Address</b> 1075 Arrow Wood Drive			
<b>Mailing Address</b>			
<b>City</b> Carmel	<b>State</b> IN	<b>ZIP</b> 46032	<b>Country</b> US
<input checked="" type="checkbox"/> Additional inventors are being named on <u>1</u> supplemental Additional Inventor(s) sheet(s) PTO/SB/02A attached hereto.			

# DECLARATION — Utility or Design Patent Application

Direct all correspondence to:  Customer Number or Bar Code Label  OR  Correspondence address below

Name JOSEPH S. TRIPOLI - PATENT OPERATIONS

Address THOMSON multimedia Licensing Inc.

Address PO Box 5312

City PRINCETON

State NJ

ZIP 08540

Country US

Telephone 609-734-9875

Fax 1-609-734-9700

I hereby declare that all statements made herein of my own knowledge are true and that all statements made on information and belief are believed to be true; and further that these statements were made with the knowledge that willful false statements and the like so made are punishable by fine or imprisonment, or both, under 18 U.S.C. 1001 and that such willful false statements may jeopardize the validity of the application or any patent issued thereon.

NAME OF SOLE OR FIRST INVENTOR :

A petition has been filed for this unsigned inventor

Given Name (first and middle [if any]) AHMET MURSIT

Family Name or Surname ESKICIOGLU

Inventor's Signature Ahmet Mursit Eskicioğlu

Date 1/30/01

Residence: City INDIANAPOLIS IN

State IN

Country US

Citizenship TR

Mailing Address 8235 Lakeshore Trail Apt. 125

Mailing Address

City Indianapolis

State IN

ZIP 46250

Country US

NAME OF SECOND INVENTOR:

A petition has been filed for this unsigned inventor

Given Name (first and middle [if any]) WILLIAM WESLEY

Family Name or Surname BEYERS

Inventor's Signature William W. Beyers

Date 2/8/2001

Residence: City Carmel IN

State IN

Country US

Citizenship US

Mailing Address 1075 Arrow Wood Drive

Mailing Address

City Carmel

State IN

ZIP 46032

Country US

Additional inventors are being named on 1 supplemental Additional Inventor(s) sheet(s) PTO/SB/02A attached hereto.

100  
200  
X  
X

X

X

Please type a plus sign (+) inside this box → +

Under the Paperwork Reduction Act of 1995, no persons are required to respond to a collection of information unless it contains a valid OMB control number.

DECLARATION	ADDITIONAL INVENTOR(S) Supplemental Sheet Page <u>3</u> of <u>3</u>
-------------	---

<b>Name of Additional Joint Inventor, if any:</b>		<input type="checkbox"/> A petition has been filed for this unsigned inventor		
Given Name (first and middle [if any])		Family Name or Surname		
IZZAT HEKMAT		IZZAT		
Inventor's Signature				Date
Residence: City	Carmel	State	IN	Citizenship US
Mailing Address 2249-6 East 151st Street				
Mailing Address				
City	Carmel	State	IN	Country US
<b>Name of Additional Joint Inventor, if any:</b>		<input type="checkbox"/> A petition has been filed for this unsigned inventor		
Given Name (first and middle [if any])		Family Name or Surname		
EDWIN ARTURO		HEREDIA		
Inventor's Signature	<i>Edwin Arturo Heredia</i>			Date March 6, 2001
Residence: City	San Jose <i>CA</i>	State	CA	Citizenship Boliva
Mailing Address <del>1700 North First Street #235</del> 1409 Whitewood Ct. <i>E.76</i>				
Mailing Address				
City	San Jose	State	CA	Country US
<b>Name of Additional Joint Inventor, if any:</b>		<input type="checkbox"/> A petition has been filed for this unsigned inventor		
Given Name (first and middle [if any])		Family Name or Surname		
YOUSEF WASEF		NIJIM		
Inventor's Signature				Date
Residence: City	Carmel	State	IN	Citizenship Jordan
Mailing Address 5808 Tanager Lane				
Mailing Address				
City	Carmel	State	IN	Country US

1  
2  
3  
4  
5  
6  
7  
8  
9  
10  
11  
12  
13  
14  
15  
16  
17  
18  
19  
20  
21  
22  
23  
24  
25  
26  
27  
28  
29  
30  
31  
32  
33  
34  
35  
36  
37  
38  
39  
40  
41  
42  
43  
44  
45  
46  
47  
48  
49  
50  
51  
52  
53  
54  
55  
56  
57  
58  
59  
60  
61  
62  
63  
64  
65  
66  
67  
68  
69  
70  
71  
72  
73  
74  
75  
76  
77  
78  
79  
80  
81  
82  
83  
84  
85  
86  
87  
88  
89  
90  
91  
92  
93  
94  
95  
96  
97  
98  
99  
100

**Burden Hour Statement:** This form is estimated to take 21 minutes to complete. Time will vary depending upon the needs of the individual case. Any comments on the amount of time you are required to complete this form should be sent to the Chief Information Officer, U.S. Patent and Trademark Office, Washington, DC 20231. **DO NOT SEND FEES OR COMPLETED FORMS TO THIS ADDRESS. SEND TO: Assistant Commissioner for Patents, Washington, DC 20231.**

+

Please type a plus sign (+) inside this box → +

Under the Paperwork Reduction Act of 1995, no persons are required to respond to a collection of information unless it contains a valid OMB control number.

<b>DECLARATION</b>	<b>ADDITIONAL INVENTOR(S) Supplemental Sheet</b> Page <u>3</u> of <u>3</u>
--------------------	---

<b>Name of Additional Joint Inventor, if any:</b>		<input type="checkbox"/> A petition has been filed for this unsigned inventor			
Given Name (first and middle [if any])			Family Name or Surname		
<u>IZZAT HEKMAT</u>			<u>IZZAT</u>		
Inventor's Signature	<u>izzat hekmat izzat</u>			Date	<u>1/25/01</u>
Residence: City	<u>Carmel IN</u>	State	<u>IN</u>	Country	<u>US</u>
Mailing Address					
<u>2249-6 East 151st Street</u>					
Mailing Address					
City	<u>Carmel</u>	State	<u>IN</u>	ZIP	<u>46033</u>
Country		<u>US</u>			
<b>Name of Additional Joint Inventor, if any:</b>		<input type="checkbox"/> A petition has been filed for this unsigned inventor			
Given Name (first and middle [if any])			Family Name or Surname		
<u>EDWIN ARTURO</u>			<u>HEREDIA</u>		
Inventor's Signature					Date
Residence: City	<u>San Jose</u>	State	<u>CA</u>	Country	<u>US</u>
Mailing Address					
<u>1700 North First Street #235</u>					
Mailing Address					
City	<u>San Jose</u>	State	<u>CA</u>	ZIP	<u>95112</u>
Country		<u>US</u>			
<b>Name of Additional Joint Inventor, if any:</b>		<input type="checkbox"/> A petition has been filed for this unsigned inventor			
Given Name (first and middle [if any])			Family Name or Surname		
<u>YOUSEF WASEF</u>			<u>NIJIM</u>		
Inventor's Signature	<u>yousef wasef nijim</u>			Date	<u>01/25/01</u>
Residence: City	<u>Carmel IN</u>	State	<u>IN</u>	Country	<u>US</u>
Mailing Address					
<u>5808 Tanager Lane</u>					
Mailing Address					
City	<u>Carmel</u>	State	<u>IN</u>	ZIP	<u>46033</u>
Country		<u>US</u>			

Burden Hour Statement: This form is estimated to take 21 minutes to complete. Time will vary depending upon the needs of the individual case. Any comments on the amount of time you are required to complete this form should be sent to the Chief Information Officer, U.S. Patent and Trademark Office, Washington, DC 20231. DO NOT SEND FEES OR COMPLETED FORMS TO THIS ADDRESS. SEND TO: Assistant Commissioner for Patents, Washington, DC 20231.

300

U.S. PATENT AND TRADEMARK OFFICE

500

+

+

+